

# TRUXTA

by **Tufftruk** Smart Equipment



## TUFFTRUK PRODUCT RANGE

MINI DUMPERS  
CONCRETE BUGGE

ATTACHMENTS  
CONVEYORS





# Contents

<b>About Us</b> .....	<b>3</b>
<b>Battery Power Barrow</b> .....	<b>6</b>
EB300 2WD	
<b>Battery Bendie Dumper Range</b> .....	<b>9</b>
EB300 / EB500 / EB800	
<b>Concrete BUGGE</b> .....	<b>20</b>
Concrete BUGGE	
<b>Petrol Bendie Dumper</b> .....	<b>23</b>
B300G / B450G	
<b>Attachments</b> .....	<b>25</b>
Poly-Skips	
Flat Bed & Log Poles	
Power-Tip & Options/Attachments	
Greedy Boards	
Tow ball	
<b>TUFFBELT Conveyor</b> .....	<b>31</b>
Micro, Mini, Maxi & Maxi Plus	



## **About Us**

The team at Tufftruk Ltd manufacture a range of **Power Barrows, Mini Dumpers, Concrete BUGGE's and Attachments** in Staffordshire in the UK.

The company has set a new standard for sustainable construction machines - battery powered smart equipment for safe and powerful materials handling.

The TRUXTA Range of mini dumpers has become a world-wide brand, sold internationally.

From 300kg to 800kg these highly engineered mini dumpers deliver compact 4x4 performance with smooth squeeze & go controls. Available with battery power for a quiet noise and emission-free environmentally friendly option.

**Smart Equipment for a Greener Environment**

## **Our Mission**

To engineer and manufacture quality equipment designed to meet the future greener environment on work sites worldwide for a sustainable world.



# TRUXTA

by **Tufftruk** Smart Equipment



- 8 HOURS RUNTIME
- OVERNIGHT SMART CHARGE
- DUAL VOLTAGE (110V/230V)



- 4X4 AND EASY TO MANOEUVRE
- EASY TO OPERATE IN TIGHT SPACE
- REGISTERED DESIGNS



- BUILT-IN MOTOR BRAKE SYSTEM
- SAFE PARKING BRAKE
- REGENERATIVE BRAKING SYSTEM

# BATTERY POWERED

## Compact Mini Dumpers

**EB300, EB500, EB800**



Tufftruk Limited introduce a range of TRUXTA mini dumpers. Battery Powered to provide maximum versatility and light touch operation.

Available as a EB300, EB500 & EB800 for use indoor or outdoor the compact TRUXTA mini dumpers offer excellent load capacity and productivity.



## *Articulated* for access

A BENDie mini dumper's articulated chassis means the TRUXTA handles corners with minimum effort - **“Just steer around bends and corners - no need to lift or reposition”**.

The compact TRUXTA mini dumpers fit through typical doorways.

The Squeeze & Go Controls (no mechanical gearboxes) makes for the easiest use for any operator.

# TRUXTA

by **Tufftruk** Smart Equipment

“Making light work of tough jobs”

The **EB300 4x2 Electric BENDie** compact battery powered barrow that provides maximum versatility and light touch operation.

The barrow is designed for use indoor or outdoor, the compact size (2ft 6”/ 730mm) comfortably fits through typical doorways.

For a compact sized mini dumper with 300kg payload the powered barrow offers excellent load capacity and productivity.

The TRUXTA 4x2 power barrow provides many benefits over a conventional style powered wheelbarrow.

- On-board smart battery charger with power cable.
- Fail-safe dead-man brake system.
- New multi-position handle.
- New heavy-duty poly-skip.
- Articulated steering
- 2 stage tipping

# BATTERY POWERED

## Power Barrow EB300 (4X2)



Model	Battery EB300 (4x2)	
Motor/Power (kW)	DC Motor 1x600W/24v	
Power Type	2 x 12v AGM Batteries	
Max Payload	300kg/660lbs / 7ft <sup>3</sup> / 0.2m <sup>3</sup>	
Unladen Weight	120kg 264lbs	
Working Width	730mm	
Working Gradient	15°	
Drive & Controls	1 x 24v Transaxle	
Brake System	Electrically operated brake system with fail-safe dead-man handle	
Standard Fitment Tyres	Flotation with option for turf tyres	
Forward Travel	0-3.5 mph / 5.63 kph	
Reverse Travel	0-1.5 mph 2.42 kph	
Noise Level (db)	< 76	
Hand Arm Vibration	< 2.5 m/s	
Skip Options	Poly or Steel	
Skip Tipping Options	Gravity tip & Power-Tip	
Compatible Attachments	OPTT15-DIO	Steel Skip Extensions (Greedy Boards)
	OPTT44-DIO	Poly Skip Extensions (Greedy Boards)

# BATTERY POWERED

## Compact Mini Dumper EB300 (4x2)

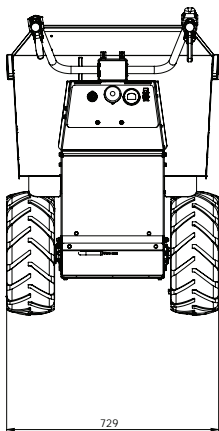
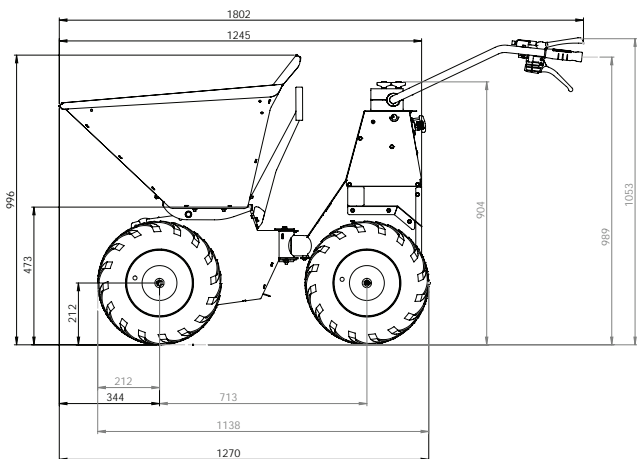





The **EB300 4x4 Electric BENDie** mini dumper - a compact battery powered mini dumper that provides maximum versatility and light touch operation.

The EB300 is designed for use indoor or outdoor, the compact size (2ft 6"/ 730mm) comfortably fits through typical doorways.

For a compact sized mini dumper with 300kg payload the EB300 offers excellent load capacity and productivity.

The TRUXTA 4x4 model with articulated design turns corners easily and gets into places tracked, lift and steer dumpers cannot. Very good over un-even terrain.

- On-board smart battery charger with power cable.
- Fail-safe dead-man brake system.
- New multi-position handle.
- New heavy-duty poly-skip.



# BATTERY POWERED

## Compact Mini Dumper EB300 (4x4)

Heavy-duty poly-skip or steel skip

Multi-position handle

Fail-safe dead-man brake system

Overnight smart charge



Model	Battery EB300 (4x4)	
Motor/Power (kW)	DC Motor 2x600W/24v	
Power Type	2 x 12v AGM Batteries	
Max Payload	300kg/660lbs / 7ft <sup>3</sup> / 0.2m <sup>3</sup>	
Unladen Weight	134kg 295lbs	
Working Width	730mm	
Working Gradient	25°	
Drive & Controls	2 x 24v Transaxle	
Brake System	Electrically operated brake system with fail-safe dead-man handle	
Standard Fitment Tyres	Flotation with option for turf tyres	
Forward Travel	0-3.5 mph / 5.63 kph	
Reverse Travel	0-1.5 mph 2.42 kph	
Noise Level (db)	< 76	
Hand Arm Vibration	< 2.5 m/s	
Skip Options	Poly or Steel	
Skip Tipping Options	Gravity Tip, Power-Tip	
Compatible Attachments	OPTT11-DIO	Tow Ball Hitch - (EB300 4x4 only)
	OPTT15-DIO	Steel Skip Extensions (Greedy Boards)
	OPTT44-DIO	Poly Skip Extensions (Greedy Boards)
	FLATBEDS	Flatbed section see page 19

# BATTERY POWERED

## Compact Mini Dumper EB300 (4x4)

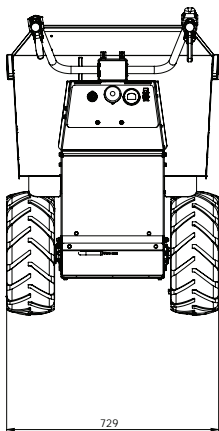
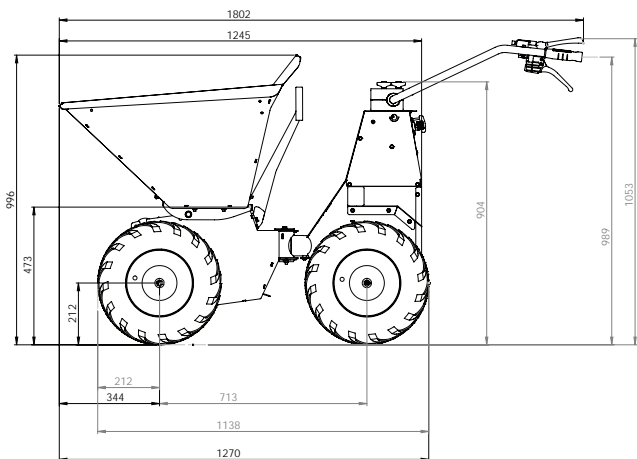



The **Electric BENDie EB500** mini dumper - a battery powered mini dumper that provides maximum versatility and light touch operation.

The EB500 is designed for use both indoor and outdoor, compact in size it fits through typical doorways (3ft/850mm) and offers excellent load capacity and productivity.

- The articulated BENDie 4x4 mini dumper provides access even in the tightest corners.
- The TRUXTA 4x4 is really compact and gets into places tracked, lift and steer dumpers cannot.
- Environmentally friendly option for use anywhere - no emissions and ultra-quiet for noise sensitive environments.
- The TRUXTA electric has a regenerative-braking system to help slow down when stopping; this generates power into battery pack, to increase efficiency and range. Now with electronic brake over-ride.
- The fail-safe dead-man brake system gives the operator the safest possible operation.
- Heavy duty drive axles with a simplified drive line for easy maintenance.
- Centre lifting point with locking-pivot for safe lifting and ease of transporting.

# BATTERY POWERED

## Compact Mini Dumper EB500 (4x4)

Heavy-duty poly-skip or steel skip

8 hours run-time



Fail-safe dead-man brake system

Overnight smart charge

Model	Battery EB500 (4x4)	
Motor/Power (kW)	DC Motor 2x750W/24v	
Power Type	2 x 12v AGM Batteries	
Max Payload	500kg/1100lbs / 12ft <sup>3</sup> / 0.35m <sup>3</sup>	
Unladen Weight	240kg 529lbs	
Working Width	850mm	
Working Gradient	25°	
Drive & Controls	2 x 24v Transaxle	
Brake System	Electrically operated brake system with fail-safe dead-man handle	
Standard Fitment Tyres	Flotation with option for turf tyres	
Forward Travel	0-3.5 mph / 5.63 kph	
Reverse Travel	0-1.5 mph 2.42 kph	
Noise Level (db)	< 76	
Hand Arm Vibration	< 2.5 m/s	
Skip Option	Poly-skip 500	Steel 500 Steel 400 (Narrow)
Skip Tipping Options	Gravity tip, Power-Tip & Power-Tip+	
Compatible Attachments	OPTT11-DIO Tow Ball Hitch OPTT34-DIO Steel Skip Extensions (Greedy Boards) (Fits also 400 skip) OPTT35-DIO Poly Skip Extensions (Greedy Boards)  Flatbeds Flatbed section see page 19	





The **Electric EB800 'Stand-On'** mini dumper - a battery powered mini dumper that provides maximum versatility and light touch operation.

**The EB800 has great payload to machine weight ratio - 800kg payload, 550kg machine.** Offering excellent load capacity and productivity.

Fold-down rear step for operator comfort on large sites.

- Battery powered driveline, with hydraulic power tipping, fast tipping cycle.
- Quick change attachments - flatbeds and skips (no tools required).
- Maximum manoeuvrability - articulated chassis design
- Zero emissions.



# BATTERY POWERED

## 'Stand On' Mini Dumper EB800 (4x4)



Model	Battery EB800 (4x4) 'Stand -On'
Motor/Power (kW)	DC Motor 2x1400W/24v
Power Type	4 x 6v AGM Batteries
Max Payload	800kg/1800lbs / 21ft <sup>3</sup> / 0.60m <sup>3</sup>
Unladen Weight	550kg 1212lbs
Working Width	885mm
Working Gradient	10° Constant Use / 15° Intermittent Use
Drive & Controls	2 x 24v Transaxle
Brake System	Electrically operated brake system with fail-safe dead-man handle
Standard Fitment Tyres	Flotation with option of turf tyres
Forward Travel	2.5 mph / 4 kph
Reverse Travel	1.5 mph / 2.5 kph
Noise Level (db)	< 82
Hand Arm Vibration	< 2.5 m/s
Skip Options	Steel
Skip Tipping Options	Power-Tip



# BATTERY POWERED

## 'Stand On' Mini Dumper EB800 (4x4)

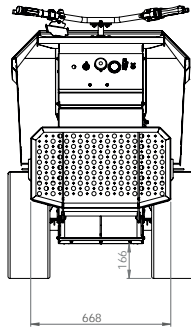
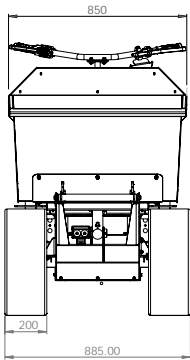
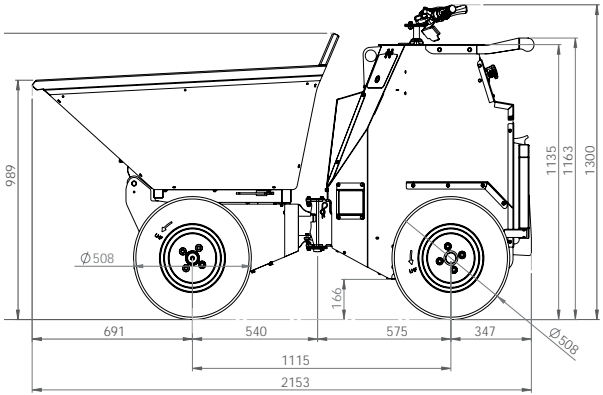

# BATTERY POWERED

## MID TIP Mini Dumper EB800PTP (4x4)



Model	Battery EB800 (4x4) 'Stand -On'
Motor/Power (kW)	DC Motor 2x1400W/24v
Power Type	4 x 6v AGM Batteries
Max Payload	800kg/1800lbs / 21ft <sup>3</sup> / 0.60m <sup>3</sup>
Unladen Weight	550kg 1212lbs
Working Width	885mm
Tip Height	960mm
Working Gradient	10° Constant Use / 15° Intermittent Use
Drive & Controls	2 x 24v Transaxle
Brake System	Electrically operated brake system with fail-safe dead-man handle
Standard Fitment Tyres	Flotation with option of turf tyres
Forward Travel	2.5 mph / 4 kph
Reverse Travel	1.5 mph / 2.5 kph
Noise Level (db)	< 82
Hand Arm Vibration	< 2.5 m/s
Skip Options	Steel
Skip Tipping Options	Power-Tip

# BATTERY POWERED

## MID TIP Mini Dumper EB800PTP (4x4)

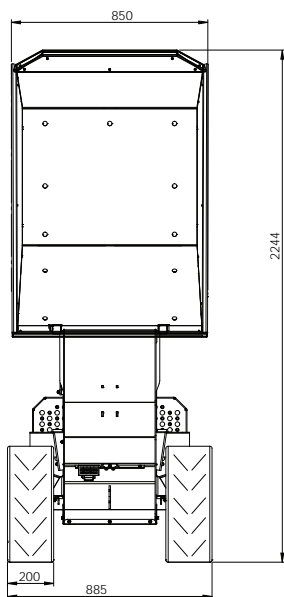
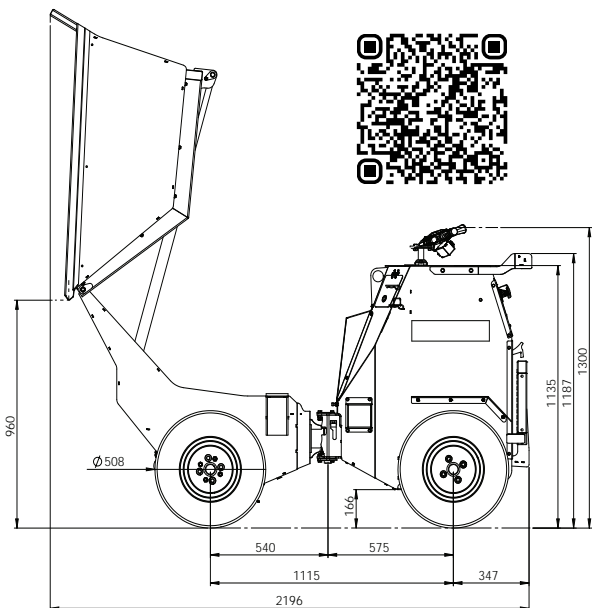



The **Electric Concrete 'Stand-On' BUGGE**  
- is a battery powered BUGGE that provides maximum versatility  
and light touch operation.

**The Concrete BUGGE has great payload to machine  
weight ratio - 720kg payload, 550kg machine.**

Offering excellent load capacity and productivity.

Fold-down rear step for operator comfort on large sites.

- Battery powered driveline, with hydraulic power tipping, fast tipping cycle.
- Quick change attachments - flatbeds and skips (no tools required).
- Maximum manoeuvrability - articulated chassis design.
- Zero emissions.
- Durable heavy duty poly skip, with anti splash return.
- Good travel speed for efficient cycle time on the job.
- Front LED work light as standard.
- Maintenance free machine.

# BATTERY POWERED

## 'Stand On' Concrete BUGGE (4x4)



Model	Battery Concrete BUGGE (4x4) 'Stand -On'
Motor/Power (kW)	DC Motor 2x1400W/24v
Power Type	4 x 6v AGM Batteries
Max Concrete Payload	720kg/1600lbs / 12.5ft <sup>3</sup> / 0.35m <sup>3</sup>
Unladen Weight	550kg 1212bs
Working Width	885mm
Working Gradient	10° Constant Use / 15° Intermittent Use
Drive & Controls	2 x 24v Transaxle
Brake System	Electrically operated brake system with fail-safe dead-man handle
Standard Fitment Tyres	Flotation
Forward Travel Reverse Travel	3.8 mph / 6.2 kph 2.4 mph / 3.8 kph
Noise Level (db)	< 82
Hand Arm Vibration	< 2.5 m/s
Skip Options	Poly
Skip Tipping Options	Power-Tip

# BATTERY POWERED

## 'Stand On' Concrete BUGGE (4x4)

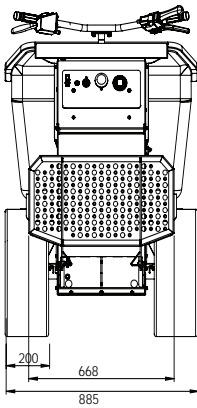
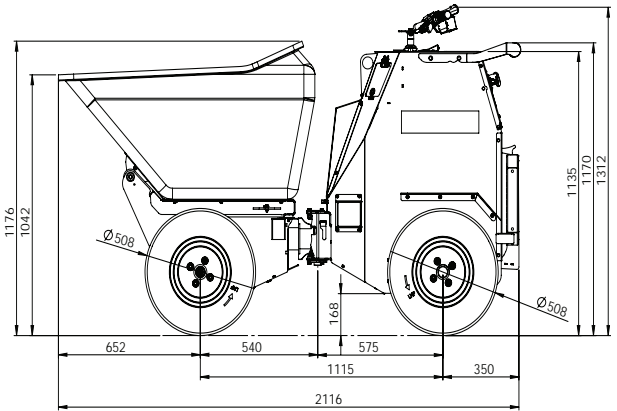



Tufftruk Limited range of TRUXTA Honda or Vanguard powered mini dumpers that provide maximum versatility and light touch operation, available with 300kg and 450kg skip capacity.

The **BENDie 4x4 mini dumper** provides access even in the tightest corners. The TRUXTA 4x4 is really compact and gets into places other units cannot.

With a large skip capacity the TRUXTA BENDie mini dumper offers excellent load capacity in and around sites and gardens.

- Robust heavy duty construction and a well-balanced skip.
- 2 stage self-tipping skip requires no manual lifting.
- Built for durability - hydrostatic system.
- Easily transportable from site to site in a large van.
- The mini dumper's articulated chassis means the TRUXTA handles corners with minimum effort.
- The well balanced TRUXTA fits through typical doorways (2ft 6" B300 or 3ft B450).

**POWERED by**  
**HONDA**™

**VANGUARD**

# PETROL POWERED

## Mini Dumper B300G & B450G (4x4)

2 stage  
self-tipping

Squeeze & go  
controls

Hydrostatic  
transmission

Honda/Vanguard  
powered  
engine



Model		Petrol B300G / GV	Petrol B450G / GV
Engine/Power (kW)/hp		Honda GX 160 (3.6) / 4.8 Vanguard 200 (3.7) / 4.9	Honda GX 200 (4.1) / 5.5 Vanguard 200 (3.7) / 4.9
Fuel Type		Unleaded Petrol (4 stroke)	
Fuel Capacity Litres		3.1	
Max Payload		300kg/660lbs / 7ft <sup>3</sup> / 0.2m <sup>3</sup>	450kg/990lbs 10.6ft <sup>3</sup> / 0.3m <sup>3</sup>
Unladen Weight	kg	170	180
	lbs	374	396
Working Width		730mm	850mm
Working Gradient		25°	25°
Drive & Controls		Hydrostatic System	
Brake System		Electrically operated brake system with fail-safe dead-man handle	
Standard Fitment Tyres		Flotation with option for turf tyres	
Forward Travel		0-4 mph / 6.444 kph	
Reverse Travel		0-1.5 mph / 2.42 kph	
Noise Level (db)		< 96	
Hand Arm Vibration		3.6 m/s	4.6 m/s
Skip Options		Steel / Poly	
Skip Tipping Options		Gravity tipping option only	
Compatible Attachments		OPTT11-DIO Tow Ball OPTT34-DIO Steel Skip Extensions (Greedy Boards) OPTT35-DIO Poly Skip Extensions (Greedy Boards)  FLATBEDS Flatbed section see page 19	



# POLY SKIP

300, 450 & 500 Capacity



The heavy duty Poly-Skip is designed for TRUXTA mini dumpers and Concrete BUGGE range with 300, 450, 500 & 800 Kg skip capacities.

Available with 2-stage manual tipping as standard or Power-Tip options.

- Constructed from durable and tough polyethylene-material.
- Low noise when loading gravel or bricks.
- Supported with steel sub-frame.
- Wear and scratches are less visible than on a steel painted skip.
- Material is 100% recyclable at the end of its life.
- Less spillage when working with wet concrete.



Part No:	Bucket
100-05800SP	300 Poly-bucket Green
100-02000SP	450 Poly-bucket Green
100-05700SP	500 Poly-bucket Green

# FLATBED & LOG POLES

730mm & 850mm Wide



Tufftruk Flatbeds are a versatile, easy to use attachment for a TRUXA mini dumper.

Heavy duty in design the flatbed is ideal for stacking and moving blocks, bricks, logs etc.

The optional log poles help secure the load.

Makes all kinds of materials handling so much easier.



Flat Bed	Compatibility with	Width
OPTT12-DIO	EB300, B300G, B450G, EB500	730mm
OPTT14-DIO	EB300, B300G, B450G, EB500	850mm
OPTT51-DIO	EB800	850mm



TRUXTA BENDIE mini dumper now available with an electric powered tipping ram for controlled skip tipping.

- The Power-Tip offers smooth controlled tipping with an electric ram for increased controllability.
- Power-Tip increases skip discharge height to 252mm – ideal for shuttering.
- Power-Tip-Plus increases skip discharge height to 589mm – ideal for trailers and conveyors.
- Option available to Retrofit a Power-Tip or Power-Tip-Plus to your Electric TRUXTA for increased skip discharge height.

Model TRUXTA	Power Tip	Power Tip Plus
300 skip discharge height mm / angle°	252 / 35°	589 / 35°
450 skip discharge height mm / angle°		589 / 35°
500 skip discharge height mm / angle°	252 / 35°	

# OPTIONS & ATTACHMENTS

Power-Tip

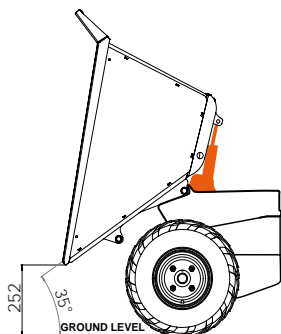

Power-Tip<sup>+</sup>

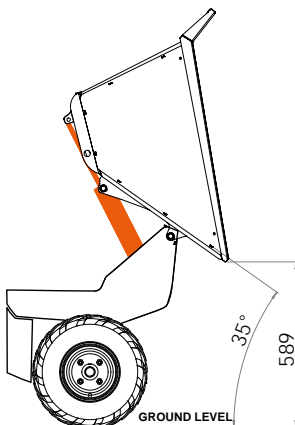

For all Electric TRUXTA mini dumpers, the Power-Tip is available as a Retrofit option.

It provides increased skip-tipping height, perfect for customers who have already invested in a TRUXTA and need more height.

Part No.	
OPTT24-D10	Power-Tip Plus 500 Steel bucket attachment - Green
OPTT31-D10	Power-Tip Plus 500 Poly bucket attachment - Green
OPTT47-D10	Power-Tip 300 Poly bucket attachment - Green
OPTT38-D10	Power-Tip 500 Poly bucket attachment - Green
OPTT39-D10	Power-Tip 500 Steel bucket attachment - Green

## *Greedy Boards*



Increase the capacity of the TRUXTA with bolt-on Greedy Boards.

Provides added volume for excess when a fully loaded with light materials.

Eg. leaves, grass, agri-foods, livestock foods etc...

## *Tow Ball*



TRUXTA with the easy-attach Tow-Ball hitch.

Efficiently and safely moves towable vehicles.

1250kg tow capacity on level ground

# ATTACHMENTS

Easy fit attachments for a variety of applications.

Greedy Boards	Compatibility with
OPTT34-DIO	EB500 (Steel)
OPTT35-DIO	EB500 (Poly)
OPTT44-DIO	EB300 & B300G (Poly)
OPTT15-DIO	B300G, B450G (Steel)
OPTT28-DIO	B450G (Poly)

Tow Ball	Compatibility with
OPTT11-DIO	EB300 (4x4), EB500, B300G + B450G





**TUFFBELT Mini-Maxi conveyors** are available in a variety of sizes from 2 to 6 metres from Tufftruk Limited.

**EFFICIENT** - a large hopper permits loading with a mini excavator and reduces material spillage.

**PRACTICAL** - the movable support allows Tuffbelt to be placed exactly above the next one. The handy hoppers ensure each conveyor belt can be loaded perfectly.

**RELIABLE** - built for hire, Tuffbelt is built for the toughest materials and construction sites.

**SIMPLE** - a simple belt scraper keeps the belts clean. Easy to maintain and adjust.

- 50 tonnes / hour with unique belt speed of 24m/min.
- A high yield, good use of capacity and long-term hire.
- An extremely robust, galvanised steel frame with an ultra-reliable rubber belt.
- A product that is easy to handle and store and very simple mechanically.
- Mini-Maxi conveyor belts satisfy the strictest safety standards.

# Tuffbelt Conveyors

## Micro, Mini, Maxi & Maxi Plus



Link connectors  
for conveyors

Heavy  
Duty Build

Robustly  
built

Technical Specification	MICRO 2M*	MINI 3 M	MAXI 4.5 M	MAXI PLUS 6M*
L x W x H (cm) *Micro & Maxi Plus, 2m, 6m lengths available to order.	243 x 49 x 34	313 (343 w. handles) x 49 x 34	448 (478 w. handles) x 49 x 34	628 x 49 x 34
Weight (kg)	80	100	135	175
Belt width (cm)	40	40	40	40
Motor Power	230 V /110 V 370 W	230 V /110 V 370 W	230 V / 110 V 500 W	230 V / 110 V 500 W
Belt speed (m/min)	24	24	24	24
Maximum rising angle	40°	40°	40°	40°
Capacity (tonnes / hour)	50	50	50	50

## Accessories

Link Connectors available for connecting Tuffbelt conveyors.



Large hopper



Small hopper



Support



Set of wheels